

Double section Wall cabinet

Features:

Disassembled and small packaging, easy to deliver and carry.
 Special design front and back frames are with good stability.
 16 screws are needed to assemble the whole enclosure. It will take only 10 minutes to assemble the enclosure by one person.
 Front door is with corrective structure to avoid door dropping. Opening direction can be changed easily.
 Cable entries are available on top, bottom and back of enclosure, suitable for different places.
 Opening direction of enclosure body can be changed quickly. Automatic locking ensures safety and reliability.
 Swing part depth is 80mm.
 Maximum Loading capacity: 30kgs
 Color: Black Ral9004, Gray Ral7035

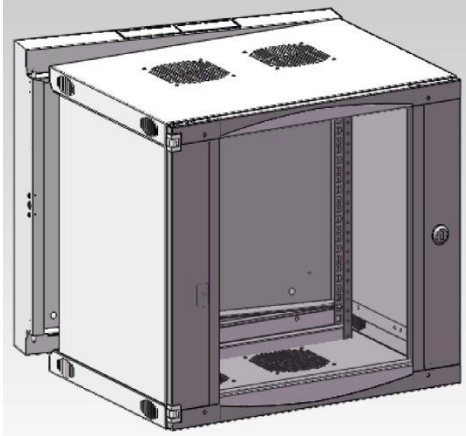
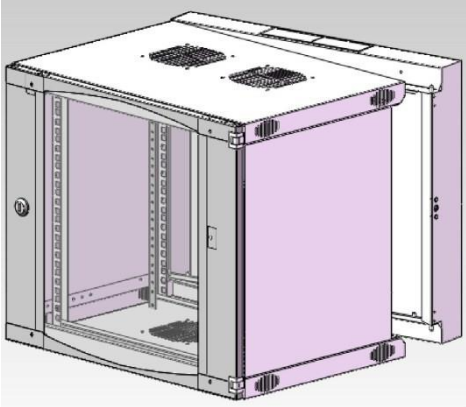

Standards:

- ANSI/EIA 310-D
- IEC60297-2
- DIN41494, PART1
- DIN41494, PART7
- Compatible with 19" International Standards, ETSI, CE, RoHS

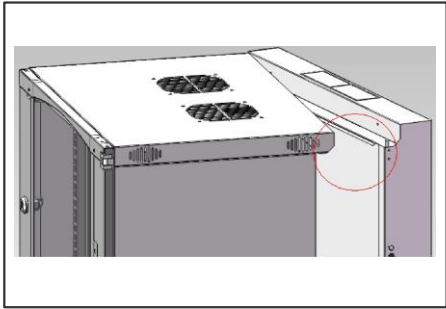

Mount panel

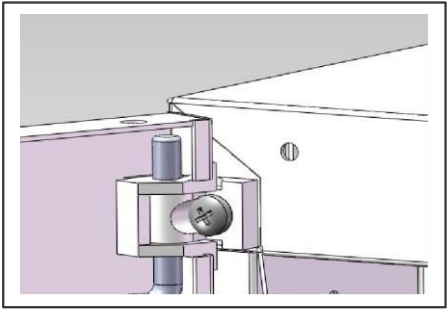

Frame

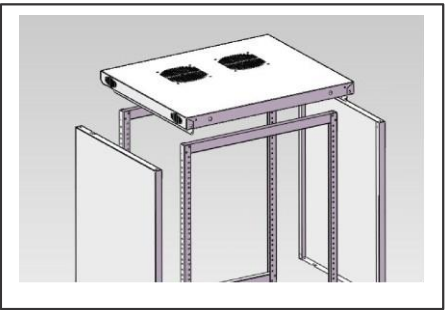

Stable structure

Optional accessories:



2U cantilever shelf



PDU

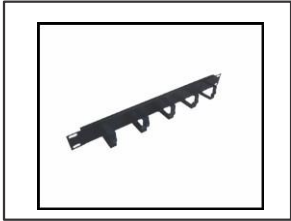

1U cable manager



Blanking panel

Structure of cabinet

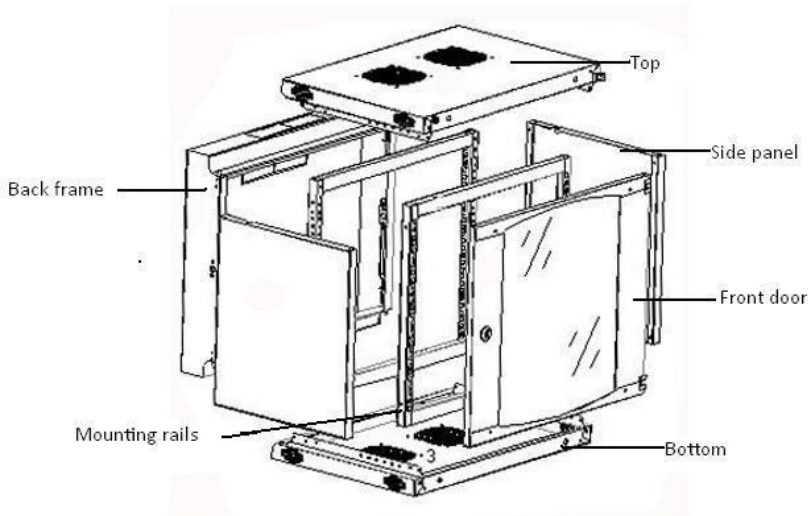

Front door options:

- 1-1: toughened glass door, with small round lock
- 1-2: toughened glass door with stripped hole border, with small round lock
- 1-3: toughened glass door with net hole border, with spring lock
- 1-4: metal plate door, with small round lock
- 1-5: perforated door, with spring lock

Main part:

S/N	Specification	Qty	Unit	Material	Surface finishing	Remark
1	Toughened glass front door (1-1)	1	pc	SPCC	Powder coated	Small round lock
2	Side panels	2	pc	SPCC	Powder coated	---
3	Frame	1	pc	SPCC	Powder coated	---
4	Top	1	pc	SPCC	Powder coated	---
5	Bottom	1	pc	SPCC	Powder coated	---
6	Mounting rails	2	pc	SPCC	Powder coated	---
7	M6 screws and nuts	20	set	---	---	10 sets for 12U lower

Dimensions of wall mount enclosure:

Width: 540mm;
600mm (520mm+80mm)

Specifications:

Model	Capacity	Height (mm)
GAB.06	6U	370
GAB.09	9U	470
GAB.12	12U	595
GAB.15	15U	725